

## **ПІДТВЕРДЖУВАЛЬНЕ ПОВІДОМЛЕННЯ**

Наказом Міністерства економічного розвитку і торгівлі України  
від 30.12.2014 № 1494

### **EN 54-13:2005**

en: Fire detection and fire alarm systems – Part 13: Compatibility assessment of  
system components

прийнято як національний стандарт  
методом підтвердження за позначенням

### **ДСТУ EN 54-13:2014**

uk: Системи пожежної сигналізації та оповіщення. Частина 13.  
Оцінювання сумісності компонентів системи  
( EN 54-13:2005 , IDT)

З наданням чинності від 2016–01–01

English version

## Fire detection and fire alarm systems - Part 13: Compatibility assessment of system components

Systèmes de détection et d'alarme incendie - Partie 13 :  
Évaluation de la compatibilité des composants d'un  
système

Brandmeldeanlagen - Teil 13: Bewertung der Kompatibilität  
von Systembestandteilen

This European Standard was approved by CEN on 28 February 2005.

CEN members are bound to comply with the CEN/CENELEC Internal Regulations which stipulate the conditions for giving this European Standard the status of a national standard without any alteration. Up-to-date lists and bibliographical references concerning such national standards may be obtained on application to the Central Secretariat or to any CEN member.

This European Standard exists in three official versions (English, French, German). A version in any other language made by translation under the responsibility of a CEN member into its own language and notified to the Central Secretariat has the same status as the official versions.

CEN members are the national standards bodies of Austria, Belgium, Cyprus, Czech Republic, Denmark, Estonia, Finland, France, Germany, Greece, Hungary, Iceland, Ireland, Italy, Latvia, Lithuania, Luxembourg, Malta, Netherlands, Norway, Poland, Portugal, Slovakia, Slovenia, Spain, Sweden, Switzerland and United Kingdom.



EUROPEAN COMMITTEE FOR STANDARDIZATION  
COMITÉ EUROPÉEN DE NORMALISATION  
EUROPÄISCHES KOMITEE FÜR NORMUNG

Management Centre: rue de Stassart, 36 B-1050 Brussels

<b>Contents</b>	<b>Page</b>
Foreword.....	3
Introduction.....	4
1 Scope.....	5
2 Normative references.....	5
3 Terms, definitions and abbreviations.....	5
3.1 Terms and definitions.....	5
4 Requirements.....	7
4.1 Compliance.....	7
4.2 Basic system requirements.....	7
4.3 Networked systems.....	7
4.4 Components.....	8
4.5 Transmission path(s).....	9
4.6 Input and output devices linked to a fire protection system.....	9
4.7 Documentation.....	10
5 Assessment methods and tests.....	11
5.1 General requirements.....	11
5.2 General test requirements.....	12
5.3 Functional test for compatibility.....	12
5.4 Functional test for connectability.....	15
5.5 Electromagnetic compatibility tests.....	16
Annex A (normative) Functions of a FDAS.....	17
Annex B (informative) Classification of functions of the FDAS.....	18
Annex C (informative) Example methodology for theoretical analysis.....	20

## Foreword

This document (EN 54-13:2005) has been prepared by Technical Committee CEN/TC 72 "Fire detection and fire alarm systems", the secretariat of which is held by BSI.

This European Standard shall be given the status of a national standard, either by publication of an identical text or by endorsement, at the latest by November 2005, and conflicting national standards shall be withdrawn at the latest by May 2007.

According to the CEN/CENELEC Internal Regulations, the national standards organizations of the following countries are bound to implement this European Standard: Austria, Belgium, Czech Republic, Denmark, Finland, France, Germany, Greece, Hungary, Iceland, Ireland, Italy, Luxembourg, Malta, Netherlands, Norway, Poland, Portugal, Slovakia, Spain, Sweden, Switzerland and the United Kingdom.

This document has been prepared in co-operation with the CEA (Comité Européen des Assurances) and with EURALARM (Association of European Manufacturers of Fire and Intruder Alarm Systems).

EN 54 is published in a series of parts. Information on the relationship between this document and other standards of the EN 54 series is given in Annex A of EN 54-1:1996.

EN 54-1 provides additional information about the components performing those functions that are listed in Annex A of this document.

## **Introduction**

The fire detection function is to detect a fire at the earliest practicable moment, and to give signals and indications so that appropriate action can be taken.

The fire alarm function is to give, at least, audible and/or visible signals to the occupants of a building who may be at risk from fire.

A fire detection and fire alarm system may combine the functions of detection and alarm in a single system, and typically consists of a number of inter-linked components including automatic fire detectors, manual call points and alarm sounders. These components are connected to control and indicating equipment by means of one or more transmission paths. All system components, including the control and indicating equipment, are also directly or indirectly connected to a power supply.

A fire detection and fire alarm system may also be linked to remote fault and fire alarm monitoring stations, and to fire protection and/or building management systems. However these systems are not considered as part of the fire detection and fire alarm system.

It is necessary that all the components constituting the fire detection and fire alarm system are compatible or connectable, and that requirements relating to the performance of the overall system are fulfilled.

Differentiation is made between components classified as components type 1 and other components classified as components type 2.

System requirements are also included for those fire detection and fire alarm systems that are linked to fire protection and/or other systems (e.g. building management systems).

## 1 Scope

This document specifies the requirements for compatibility and connectability assessment of system components that either comply with the requirements of EN 54 or with a manufacturer's specification where there is no EN 54 standard. This document only includes system requirements when these are necessary for compatibility assessment.

This document also specifies requirements for the integrity of the fire detection and fire alarm system when connected to other systems.

This document does not specify the manner in which the system is designed, installed and used in any particular application.

This document recognizes that it is not practical to assess the compatibility or connectability of components in all possible configurations. Methods of assessment are specified to reach an acceptable degree of confidence within pre-determined operational and environmental conditions.

This document specifies requirements related to compatibility and connectability assessment methods and tests for the system components.

This document is applicable to systems where the components are connected to control and indicating equipment and where the components are interconnected by electrical wires.

For fire detection and fire alarm systems that use other means of interconnection (for example optical fibre or radio frequency links), this document may be used as guidance.

NOTE Other European Standards are expected to cover the requirements of the other systems to which the fire detection and fire alarm system may be connected.

## 2 Normative references

The following referenced documents are indispensable for the application of this document. For dated references, only the edition cited applies. For undated references, the latest edition of the referenced document (including any amendments) applies.

EN 54-1:1996, *Fire detection and fire alarm systems — Part 1: Introduction*

EN 54-2:1997, *Fire detection and fire alarm systems — Part 2: Control and indicating equipment*

EN 50130-4, *Alarm systems — Part 4: Electromagnetic compatibility — Product family standard: Immunity requirements for components of fire, intruder and social alarm systems*

EN 60068-1, *Environmental testing — Part 1: General and guidance (IEC 60068-1:1988 + Corrigendum 1998 + A1:1992)*

## 3 Terms, definitions and abbreviations

### 3.1 Terms and definitions

For the purposes of this document, the terms and definitions given in EN 54-1:1996 and the following apply.

#### 3.1.1

##### **compatibility**

ability of a component type 1 to operate with control and indicating equipment:

## EN 54-13:2005 (E)

- within the limits specified for each component;
- within the specified limits given by the relevant parts of EN 54 if available, or given by the manufacturer if not available;
- within specified configurations of systems

### 3.1.2

#### **component type 1**

device performing a function for the protection of life and/or property that is required by European or national guidelines or regulations

### 3.1.3

#### **component type 2**

device performing a function for the protection of life and/or property that is not required by European or national guidelines or regulations

EXAMPLE      A printer used for listing fire events.

### 3.1.4

#### **configuration**

topological arrangement of components connected through transmission paths to control and indicating equipment

### 3.1.5

#### **connectability**

ability of component type 2 to operate without jeopardizing the performance of the fire detection and fire alarm system

### 3.1.6

#### **control and indicating equipment**

CIE

component of a fire detection and alarm system through which other components may be supplied with power (see EN 54-1)

### 3.1.7

#### **fire detection and fire alarm system**

FDAS

group of components including a CIE which, when arranged in (a) specified configuration(s), is capable of detecting and indicating a fire, and giving signals for appropriate action

### 3.1.8

#### **fire protection system**

FPS

group of devices that in combination are capable of automatically actuating measures to limit the effect of fire

EXAMPLE      Compartmentation systems, smoke control systems and fixed firefighting systems.

### 3.1.9

#### **hierarchical system**

networked system in which one control and indicating equipment is designated as the main control and indicating equipment, and in which the main control and indicating equipment is able to:

- receive signals from and/or transmit signals to the control and indicating equipment of a subsystem;
- indicate the status of the control and indicating equipment of a subsystem

**3.1.10**

**input/output device**

device that is connected to a transmission path of a fire detection and fire alarm system and is used to receive and/or transmit information to, from or within the system

**3.1.11**

**networked system**

fire detection and fire alarm system in which more than one control and indicating equipment are interconnected and able to exchange information

**3.1.12**

**subsystem**

part of a hierarchical system which includes only one control and indicating equipment

**3.1.13**

**transmission path**

physical connection between the components (external to the housing of the components) used for the transmission of information and/or power

## **4 Requirements**

### **4.1 Compliance**

In order to comply with this standard, the system design and compatibility or connectability of its components shall meet the requirements of this clause. This shall be verified by assessment (5.1) with reference to the required documentation (4.7), shall be tested (if necessary) as described in 5.2 to 5.5 and shall meet the requirements of the tests.

### **4.2 Basic system requirements**

System requirements can also be stated in national application guidelines (also known as codes of practice). Suppliers of components shall ensure that they:

- meet the requirements of this document;
- meet the requirements of the relevant part of EN 54;
- meet the requirements of the application guidelines of the countries where the components are intended to be placed on the market.

**4.2.1** The FDAS under consideration shall carry out fire detection functions identified in Annex A. All the different system configurations intended to be used shall be mentioned within the supplier documentation.

**4.2.2** If a function of a FDAS is shared with any other system, it shall not jeopardize the FDAS. Shared functions shall meet the most onerous requirements of the relevant specifications.

**4.2.3** If a non-FDAS function is performed by a component of a FDAS, this function shall not jeopardize the FDAS.

### **4.3 Networked systems**

#### **4.3.1 General requirements**

**4.3.1.1** A system fault (as described in EN 54-2) in one CIE shall not affect more than this CIE and the associated components controlled by this CIE.



## EN 54-13:2005 (E)

**4.3.1.2** A single fault on a transmission path connecting one CIE to another CIE shall not adversely affect the correct functioning of any part of the networked system.

**4.3.1.3** Means shall be provided for the indication of a fault on a transmission path connecting one CIE to another CIE.

### 4.3.2 Specific requirements for hierarchical systems

**4.3.2.1** A fire alarm condition on a CIE shall be indicated on the main CIE within 20 s.

**4.3.2.2** A fault warning condition on a CIE shall be indicated on the main CIE within 120 s.

**4.3.2.3** A fault or faults in a single transmission path connecting one or more CIE(s) to the main CIE shall not adversely affect the mandatory (as defined in EN 54-2) functions of the hierarchical system.

**4.3.2.4** A fault on a transmission path connecting a CIE to the main CIE shall be at least indicated on the main CIE.

**4.3.2.5** Where faults exist in more than one transmission path connecting one or more CIE(s) to the main CIE, it shall be clearly indicated on the main CIE which part(s) is (are) lost.

**4.3.2.6** The main CIE shall indicate at least general conditions (see conditions defined in EN 54-2).

**EXAMPLE** An example of a general condition is a fire condition at a subsystem CIE.

If detailed information is provided then it shall be consistent throughout the system.

**EXAMPLE** An example of provision of detailed information is a fire condition on a zone of a subsystem CIE.

**4.3.2.7** At the main CIE, it shall be possible to identify the subsystem from which the information originated.

**4.3.2.8** At the main CIE, it may be possible to operate either general manual controls or individual manual controls, but the result shall be identical to that achieved by the operation of these controls on the CIE of the subsystem.

**NOTE** Where faults exist in more than one transmission path connecting one or more CIE to the main CIE, the mandatory (as defined in EN 54-2) functions of the hierarchical system can be affected. In that case, it is preferable to connect the device type "E" (as defined in EN 54-1) directly to each CIE.

### 4.3.3 Specific requirements for software

Any software that is used for networking shall conform to EN 54-2:1997, Clause 13.

## 4.4 Components

### 4.4.1 Classification

**4.4.1.1** The components of the system are classified as component type 1 or component type 2, as defined in 3.1.2 and 3.1.3.

**NOTE** Annex A provides additional guidance.

**4.4.1.2** If a component includes one or more controls which perform functions described in EN 54-2 as being mandatory, or an optional function with requirements at the CIE, then the device shall be classified as a component type 1.

#### 4.4.2 Requirements

**4.4.2.1** To be compatible, components type 1 shall operate within the specified limits given by the relevant part of EN 54, within specified system configurations and within the limits specified for each component.

**4.4.2.2** Components type 1 that are not covered by a product standard shall conform to EN 54-1:1996, Clause 4, compliance. In addition, these components shall also conform to the EMC immunity characteristics of EN 50130-4.

**4.4.2.3** To be connectable, a component type 2 shall operate without jeopardizing the operation of the system.

**4.4.2.4** The operation of a remote control shall have the same effect as if the operation had been undertaken at the CIE.

#### 4.5 Transmission path(s)

**4.5.1** A single fault on a transmission path shall not affect another transmission path. If this is not the case, then all transmission paths adversely affected by this single fault shall be considered as a single transmission path.

**4.5.2** The facility (technical means) provided for minimizing the effect of a fault on a transmission path shall complete the restoration within 300 s.

**4.5.3** The consequence of a single interruption shall not be more serious than the consequence of a short circuit.

**4.5.4** A fault on a transmission path to any other system shall not adversely affect the correct functioning of the FDAS.

NOTE Application guidelines may require that the consequences of a fault (for example a short circuit or an interruption) on a transmission path are limited.

#### 4.6 Input and output devices linked to a fire protection system

##### 4.6.1 General requirements

Input and output devices linked to a fire protection system shall be considered as component type 1.

The documentation shall include the specifications of the input/output signals of each input/output device.

NOTE 1 The transmission path between the systems is monitored either by the FDAS or by the FPS. Details should be included within the documentation.

NOTE 2 The FDAS includes the whole of the input device transferring signals from the FPS to the fire detection and fire alarm system and the whole of the output device transferring signals from the fire detection and fire alarm system to the fire protection system. (Figure 1 shows this arrangement).

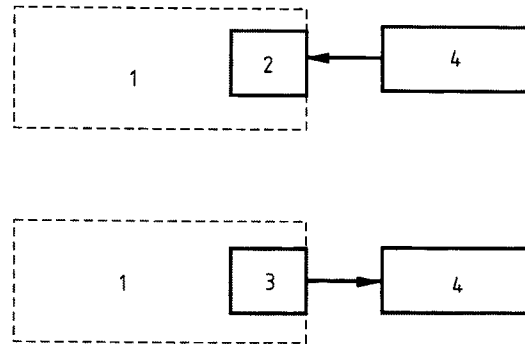

**Key**

- 1 Fire detection and fire alarm system
- 2 Input device
- 3 Output device
- 4 Fire protection system

**Figure 1 — Input/output devices linked to a fire protection system**

**4.6.2 Input device transferring signals from a fire protection system**

If a device of an FPS passes signals to the FDAS then the CIE of the FDAS shall enter the appropriate functional condition. Signals from the FPS shall be clearly identifiable as originating from the FPS.

**EXAMPLE 1** Input devices may transfer signals of a fire detected by a sprinkler system: this is indicated as a fire alarm condition.

**EXAMPLE 2** Input devices may transfer signals of a fault in the wiring of a fixed firefighting system: this is indicated as a fault warning condition.

**4.7 Documentation**

**4.7.1 General**

The system documentation shall include documentation for compatibility and, if necessary, for connectability.

**NOTE** Documentation, prepared by the supplier, allows the testing authority to make the assessment of compatibility and connectability within the configuration(s) defined by the supplier.

**4.7.2 Documentation for compatibility**

To allow the assessment of compatibility of a FDAS to be completed, the following documents shall be supplied:

- a) a list of components type 1 that make up the FDAS with a unique identification of each component including software versions;
- b) technical information facilitating the justification of compatibility;
- c) necessary evidence (e.g. test reports or certificate of conformity) for the conformity of the components to the relevant part of the EN 54;

- d) characteristics of the transmission path(s) between each component and the CIE including the specifications of cables;
- e) the limits of use of the system (configuration, number of components, functional limits, etc.).

#### 4.7.3 Documentation for connectability

To allow the assessment of connectability to be completed, the following documents shall be supplied:

- a) a list of the components type 2 intended to be used in conjunction with the FDAS with a unique identification of each component and its functions (part of the unique identification including the software version if it is involved in connectability). If component type 2 is connected through a common standardized interface, the unique identification is not needed;
- b) technical information facilitating the justification of the connectability of component type 2;
- c) characteristics of the transmission path(s) between each component and the CIE including the specifications of cables;
- d) the limits of use of the system (configuration, number of components, functional limits etc.).

#### 4.7.4 Software documentation

**4.7.4.1** If, in addition to the software used for the component, the system functionality needs the implementation of additional software, this software shall be documented in accordance with EN 54-2:1997, Clause 13.

**4.7.4.2** A list of the software versions used in the different system configuration(s) shall be supplied.

## 5 Assessment methods and tests

### 5.1 General requirements

**5.1.1** To assess the compatibility or connectability, a theoretical analysis shall be undertaken for each component and its type of transmission path, and the result shall indicate whether a functional test is necessary.

NOTE An example of the methodology for the theoretical analysis is given in Annex C.

The compatibility or connectability of each component shall be assessed in the specified system configuration(s).

**5.1.2** The electromagnetic compatibility immunity tests shall be carried out if the theoretical analysis clearly indicates that they are necessary. Testing is not necessary if each individual component conforms to the electromagnetic compatibility requirements included in the relevant product standard, and the same cable and its termination requirements specified by the relevant manufacturer is used.

**5.1.3** The test programme shall be undertaken after the theoretical analysis and will be dependant upon the results of this analysis.

NOTE The test programme may be undertaken as part of a programme to assess the performance of a device according to a part of EN 54.

## **5.2 General test requirements**

### **5.2.1 Standard atmospheric conditions for tests**

Unless otherwise stated in a test procedure, the testing shall be carried out after the test specimen has been allowed to stabilize in the standard atmospheric conditions for testing as described in EN 60068-1:1994 as follows:

- a) Temperature            15 °C to 35 °C;
- b) Relative humidity      25 % to 75 %;
- c) Air pressure            86 kPa to 106 kPa.

If variations in these parameters have a significant effect on a measurement, then such variations shall be kept to a minimum during a series of measurements carried out as part of one test on one specimen.

### **5.2.2 Mounting and electrical connection**

**5.2.2.1**     The components shall be mounted by the normal means of mounting indicated by the manufacturer.

**5.2.2.2**     The input and output connections shall be made in accordance with the manufacturer's instructions.

**5.2.2.3**     If more than one type of cable is specified, each test shall be carried out with the one considered to be the least favourable.

## **5.3 Functional test for compatibility**

### **5.3.1 The objective of the test**

The objective of the test is to check the compliance of the components in a defined configuration covered by the specifications given by the manufacturer and within the limits given in the relevant parts of EN 54.

### **5.3.2 Test schedule**

**5.3.2.1**     A test schedule shall be drawn up in order to check if the components exercise their functions (fire alarm, fault warning, disabled condition, test condition etc.) correctly within the specifications given by the manufacturer and the relevant part of EN 54, indicating that the components are fully operational.

**5.3.2.2**     During testing, implemented functions of the FDAS shall be activated in sequence (except when it is specified differently).

**5.3.2.3**     Each functional test shall be carried out at:

- the minimum supply voltage of the CIE with the maximum load on all transmission paths;
- the maximum supply voltage of the CIE with the minimum load on all transmission paths.

NOTE 1     The load includes the number of components and the length of the cables.

NOTE 2     The maximum load on all transmission paths means that at least one transmission path is fully loaded. The other transmission path(s) may either be fully loaded or have their load simulated.

NOTE 3 The minimum load on all transmission paths means that at least one transmission path is loaded with one component under consideration and there is no load on the other transmission path(s) unless it is necessary for the functional test.

**5.3.2.4** During each of the conditions given in 5.3.3 to 5.3.6, the power and/or data parameters on the transmission path shall be within the manufacturer's specifications for the connected components.

### **5.3.3 Fire alarm condition**

#### **5.3.3.1 Procedure**

Start from the quiescent condition. Activate and reset one or more of the components (detector, manual call point or input element) that can be connected to the transmission path in accordance with the manufacturer's instructions under the conditions specified in 5.3.2.

#### **5.3.3.2 Criteria of acceptance**

The following criteria of acceptance shall be met for the functional test of the fire alarm condition:

- the activation of one component or two components simultaneously (if it is technically possible for two components to simultaneously enter the fire alarm status) with subsequent activation of further components shall lead to the fire alarm condition of the system;
- resetting shall return the system to the quiescent condition.

### **5.3.4 Fault warning condition**

#### **5.3.4.1 Open circuit on a transmission path**

##### **5.3.4.1.1 Procedure**

Start from the quiescent condition. Influence the transmission path by means of serial resistances, to ascertain at which line-parameters a fault is signalled at the CIE. The serial resistance that causes the fault is called  $S_{\text{fault}}$ .

##### **5.3.4.1.2 Criteria of acceptance**

The following criteria of acceptance shall be met for the functional test of the fault warning condition:

- the fault shall cause the intended fault warning condition of the system;
- at a line-parameter  $0,9 \times S_{\text{fault}}$ , the components connected to the transmission path shall be fully operational.

#### **5.3.4.2 Short circuit on a transmission path**

##### **5.3.4.2.1 Procedure**

Start from the quiescent condition. Influence the transmission path by means of parallel resistances, to ascertain at which line-parameters a fault is signalled at the CIE. The parallel resistance that causes the fault is called  $P_{\text{fault}}$ .

## **EN 54-13:2005 (E)**

### **5.3.4.2 Criteria of acceptance**

The following criteria of acceptance shall be met for the functional test of a short circuit on a transmission path:

- a fault shall cause the intended fault warning condition of the system;
- at a line parameter  $1,1 \times P_{\text{fault}}$ , the components connected to the transmission path shall be fully operational.

### **5.3.4.3 Interruption of mains power supply**

#### **5.3.4.3.1 Procedure**

Start from the quiescent condition. Reduce the battery voltage, with the mains voltage disconnected, by discharge of the battery, or by simulation:

- until activation of a deep discharge protection device, followed by reconnection to the mains line supply; or
- until the voltage reaches a level below which the system does not operate, followed by reconnection to the mains line supply.

The simulation of a reduction of the battery voltage shall not be at a rate greater than 0,4 V/min.

#### **5.3.4.3.2 Criteria of acceptance**

The indication of the fire alarm condition shall not be activated, and the outputs to fire alarm devices (item C of Figure 1 of EN 54-1:1996), fire alarm routing equipment (item E of Figure 1 of EN 54-1:1996) and fire protection equipment (item G of Figure 1 of EN 54-1:1996) shall not be activated.

After reconnection to the mains supply and, if necessary, the resetting of a deep discharge protection device, the system shall return to the intended functional condition (except the fire alarm condition).

NOTE The intended functional condition is one of those mentioned in EN 54-2 and is specified in the manufacturer's documentation.

### **5.3.5 Disablement condition**

#### **5.3.5.1 Procedure**

Start from the quiescent condition. Disable and re-enable different system components or system parts (e.g. detectors, detector zones and transmission path).

#### **5.3.5.2 Criteria of acceptance**

The following criteria of acceptance shall be met for the functional test of the disablement condition:

- disablement shall cause the intended disablement condition of the system;
- disabled system components or system parts shall no longer have a functional effect on the system;
- after re-enablement, the system part or component shall function again as intended.

#### **5.3.6 Test condition (if provided)**

##### **5.3.6.1 Procedure**

Start from the quiescent condition. Activate the test function for various system parts or components provided for this purpose (e.g. detectors, detector zones).

##### **5.3.6.2 Criteria of acceptance**

The following criteria of acceptance shall be met for the functional test of the test condition:

- activation shall cause the intended test condition of the system;
- system parts or components, for which the test state is activated, shall function as intended under this state. After de-activation of the test function, the appropriate part of the system or component shall again be fully operational.

#### **5.4 Functional test for connectability**

##### **5.4.1 The objective of the test**

The objective of the test is to check that the component type 2 used in conjunction with the FDAS in a defined configuration covered by the specifications given by the manufacturer does not jeopardize the FDAS.

##### **5.4.2 Test schedule**

**5.4.2.1** A test schedule shall be drawn up in order to check that the components type 1 (including CIE) of the FDAS function satisfactorily when the component type 2 is used.

During testing, implemented functions of the FDAS shall be activated in sequence (except when it is specified differently).

**5.4.2.2** Each functional test shall be carried out under the same condition as mentioned in 5.3.2.3.

##### **5.4.3 Test for connectability**

###### **5.4.3.1 Procedure**

Start from the quiescent condition or fire alarm condition. Activate and reset one or more of the functions included in the component type 2 that can be connected to the transmission path, in accordance with the manufacturer's instructions under the conditions specified in 5.4.2.



**5.4.3.2 Criteria of acceptance:**

The following criteria of acceptance shall be met for the test for connectability:

- the activation (or the failure) of the component type 2 shall not prevent the correct functioning of the components type 1 of the system;
- information concerning conditions of the FDAS delivered by the components type 2 shall not be in conflict with that given by components type 1.

NOTE The failure of component type 2 may cause the fault warning condition of the system.

**5.5 Electromagnetic compatibility tests**

**5.5.1 The objective of the tests**

The objective of the tests is to check that the functioning of the system is not adversely affected.

**5.5.2 Test schedule**

The test schedule shall be selected from those defined for components within the relevant standard.

The test shall be conducted together with the component(s) to which the system is connected according to the defined configuration.

**5.5.3 Criteria of acceptance**

The correct functioning of the system shall not be adversely affected.

## Annex A (normative)

### Functions of a FDAS

Figure A.1 is based upon Figure 1 of EN 54-1:1996, but refers to functions and is not intended to represent physical components. It states the functions that are included within a FDAS (functions included in the dotted line). Where the functions bridge the dotted line they are shared between the FDAS and another system.

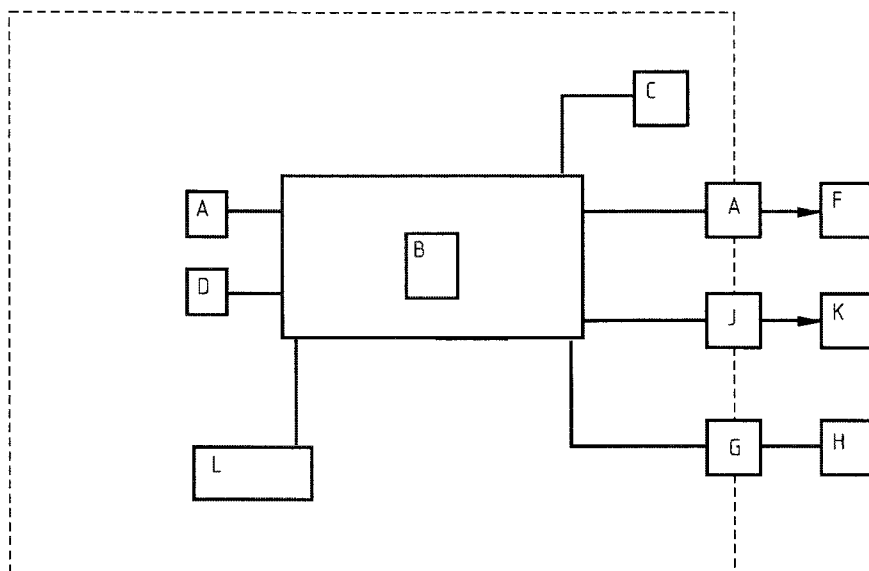

#### Key

- A Automatic fire detection function
- B Control and indicating function
- C Fire alarm function
- D Manual initiating function
- E Fire alarm routing function
- F Fire alarm receiving function
- G Control function for automatic fire protection function
- H Automatic fire protection function
- J Fault warning routing function
- K Fault warning receiving function
- L Power supply function

Figure A.1 — Functions of the fire detection and fire alarm system

## **Annex B** (informative)

### **Classification of functions of the FDAS**

#### **B.1 General**

The purpose of this Annex is to assist in the classification of the components type 1 and type 2.

#### **B.2 Fire detection function**

All detectors, such as heat, smoke, flame, gas, point- or line-type, and manual call points should be considered as being essential and therefore be classified as component type 1. All forms of components that allow the detectors to operate, such as short-circuit-isolators, the interface to connect spur-wired detectors to a loop, etc. should also be classified as type 1.

#### **B.3 Fire alarm function**

##### **B.3.1 Alarm to occupants in the premises**

This is clearly an essential function; so all components being able to perform an alarm for people should be classified as component type 1.

EXAMPLE      Sirens, voice sounders, voice alarm components, etc.

When the alarm is passed through mobile phones or pagers, an output device is needed which is classified as component type 1. All connected elements, such as computers, telephone switch boards, recorders for the messages, are not considered as part of the FDAS.

##### **B.3.2 Alarm to summon external assistance (usually the fire brigade)**

If the connection to this organization is required, then the component should be classified as component type 1.

#### **B.4 Activation of fire protection function**

##### **B.4.1 Equipment directly triggered by the FDAS**

The output function (terminals of the CIE or output device) used for the control of door holding magnets, closing dampers, smoke ventilation, ventilation control, etc. should be regarded as essential. Each component used for triggering such equipment should be classified as component type 1.

##### **B.4.2 System driven by the information coming from the FDAS**

The output device driving fire extinguishing systems, smoke control system, compartment system, release of access control system, etc. should be regarded as essential. Each component used for triggering such a system should be classified as component type 1.

### **B.5 External indication 1 (remote panels, fire brigade panels, etc.)**

The classification of component type 1 or type 2 may depend on local regulations.

Fire brigade panels should be classified as component type 1 if the fire brigades require a fire brigade panel as a mandatory component.

Remote panels should be classified as component type 1 if the CIE is in a separate location somewhere in the building and the remote panel is the usual way to access the information.

Remote panels should be classified as component type 2 when they are used to provide redundant information, such as a panel located in the office of the building manager.

### **B.6 External indication 2 (printers, building management systems, etc.)**

These components should be classified as component type 2, and include devices used to transmit information to the building management system or to all other non-security applications.

### **B.7 Input function**

Any devices that perform an input function should be classified as component type 2.

If they are used to receive fire alarm information from other kinds of detection such as a sprinkler system, they should be classified as component type 1.

### **B.8 Output function**

Any devices that perform an output function should be classified as component type 2.

If they are used to send fire alarm information to the fire protection system, they should be classified as component type 1.

### **B.9 Connection devices between transmission paths (gateway, etc.)**

Such devices should be classified as component type 1.

NOTE Junction boxes should not be considered as component type 1 or type 2.

## **Annex C** **(informative)**

### **Example methodology for theoretical analysis**

#### **C.1 Introduction**

The components forming a FDAS are designed to provide a system with a particular aspect of its overall functionality. Only when all the components are connected together is the system likely to perform in the desired manner and then only if the components intercommunicate effectively.

For the purposes of this document, the CIE is the focal point of the system and all other components are required to communicate effectively with the CIE. Communication does not only require the consideration of communication protocols; other aspects such as power supply requirements and data transmission characteristics should also be considered.

#### **C.2 Method of test**

##### **C.2.1 General**

The theoretical analysis should commence with a review of the system configuration documentation. The objective of the review is to understand the most onerous configurations and analyse their performance. A structured approach should then be followed which analyses at least the following characteristics:

- mechanical connections;
- power supply;
- data exchange;
- functionality;
- electromagnetic compatibility.

As far as possible, the analysis should be undertaken in the order stated. However, environmental compatibility should be considered throughout the analysis process and additional analysis may be considered necessary.

##### **C.2.2 List of characteristics**

###### **C.2.2.1 Mechanical connections**

Check that the mechanical arrangements for the termination of the transmission path and its connection to the component are compatible with the cable and any accessories specified for the transmission path.

## **C.2.2.2 Power supply and distribution analysis**

### **C.2.2.2.1 Voltage range**

Check that the maximum voltage of the power supply under all load conditions is less than or equal to the maximum specified voltage of the powered components.

Check that the minimum voltage provided by the power supply under all load conditions is greater than or equal to the minimum voltage of the powered component taking into account the effects of voltage drops within transmission paths.

### **C.2.2.2.2 Current**

Check that the current available from the power supply circuit is adequate to meet the maximum demands. Ensure that appropriate measures are taken to limit the current that can flow throughout the circuit to a safe level.

### **C.2.2.2.3 Supply characteristics**

Check that the component is able to function correctly with the supplied power.

**EXAMPLE** Check that the component operates with the power supply's worst case characteristics of output frequency, modulation, distortion and phase angle.

### **C.2.2.2.4 Tolerances**

Check that the components operate satisfactorily when they are subjected to worst case tolerances of the power supply. These tolerances should take into account at least the likely effect of environmental temperature and input voltage variations.

### **C.2.2.2.5 Fault performance**

If a short circuit fault occurs on a transmission path used for power distribution, check that this will be handled in an acceptable manner.

**EXAMPLE** Ensure that appropriate current limiting components are provided to prevent unacceptable losses of power during conditions of current overload.

## **C.2.2.3 Data exchange analysis**

### **C.2.2.3.1 General**

All active components connected to transmission paths rely on data being received or transmitted to perform their functions. The data may be exchanged on the same transmission path as the power supply or may be exchanged via a separate transmission path. The analysis, however, should follow the same method in both cases.

### **C.2.2.3.2 Transmission characteristics**

#### **C.2.2.3.2.1 General**

Check that the electrical characteristics of the transmission signals are compatible with the requirements for the successful reception of the data by other components on the transmission path. At least, the following characteristics should be analysed.

## **EN 54-13:2005 (E)**

### **C.2.2.3.2.2 Voltage range**

Check that the maximum transmitted signal voltage under all normal load conditions is less than or equal to the maximum specified voltage of the receiving components.

Check that the minimum transmitted signal voltage under normal load conditions is greater than or equal to that specified for the receiving components when taking into account the effects of voltage drops within transmission paths.

### **C.2.2.3.2.3 Current**

Check that the signal current flowing as a result of the operation of the transmitting component is adequate to meet the demands of the receiving components.

Check that adequate signal-current-limiting facilities are provided to protect components against over current conditions.

### **C.2.2.3.2.4 Timing**

Check that the time related characteristics of the transmitted signals are within the limits of those required by the receiving components.

### **C.2.2.3.2.5 Distortion/phase angles**

Check that the impedance characteristics regarding distortion and phase angles specified for the transmission path are compatible with the values specified for the receiving component by the manufacturer under all load conditions.

### **C.2.2.3.2.6 Tolerances**

Ensure that the receiving components will be able to successfully receive the data even under worst case tolerances of the transmitted data and transmission path characteristics.

### **C.2.2.3.2.7 Fault performance**

If a fault, either open or short circuit, occurs on a transmission path, ensure that it will be handled as required in this document.

### **C.2.2.3.3 Transmission protocol(s)**

Check that the data being exchanged between components on the transmission path is in a format that permits all components to effectively transmit and/or receive relevant data.

Check that there is a protocol for each transmission path that will permit all the components on the transmission path to exchange data and function as specified.

## **C.2.2.4 Functionality**

### **C.2.2.4.1 General**

All components connected on a transmission path should have a defined functionality that is specified in supporting documentation.

**C.2.2.4.2 Received data**

Check that the data received by the component is sufficient to permit it to perform as specified in the supporting documentation.

**C.2.2.4.3 Transmitted data**

Check that the data transmitted by the component is sufficient to permit other components on the same transmission path to perform as specified in the supporting documentation.